

Fiji LX

H 125
P 63 • 78
L 4 • 6 • 7 • 9 • 120 • 140

Gelato

	TN Chiller	TB Freezer	TB/TN Dual Temp
RS-Static			
RV-Ventilated		•	
TCS-Heated			
CH-Chocolate			

Installation
Plug-in

Temperature
-16/-14 °C

Refrigerant
R404A

Refrigeration
Ventilated

Compressor
Hermetic

Defrost
Hot gas

Climate class
7

Upper class
Tempered

Front glass
Tempered

Side glass
Tempered

Rear closing system
Tilting panel

Work top
White prepainted sheet

Lighting
Led 5700 K

Equipment handling
Swivel casters with brake

Installazione
Plug-in

Temperatura
-16/-14 °C

Refrigerante
R404A

Refrigerazione
Ventilata

Compressore
Ermetico

Sbrinamento
Gas caldo

Classe climatica
7

Vetro superiore
Temperato

Vetro frontale
Temperato

Vetri laterali
Temperato

Chiusura posteriore
Ribaltina basculante

Piano di servizio
Lamiera preverniciata bianca

Illuminazione
Led 5700 K

Movimentazione
Ruote pivotanti con freno

Internal color
Colore interno

White

Front color
Colore frontale

White

Sides color
Colore fianchi

White













Fiji LX

	4	6	7	9
External dimensions (LxDxH) Dimensioni esterne (LxPxH)	824x630x1247 mm	1214x630x1247 mm	1354x630x1247 mm	1659x630x1247 mm
Capacity (gross/net) Capacità (lorda/netta)	218 / 119 Lt	339 / 185 Lt	383 / 209 Lt	478 / 261 Lt
Net weight Peso netto	67 kg	99 kg	110 kg	135 kg
Refrigeration Refrigerazione	Ventilated Ventilata			
Refrigerant Refrigerante	R290			
Climate class Classe climatica	7			
Operating conditions Condizioni ambientali	35 °C / 75 %RH			
Product temperature Temperatura prodotto	-16/-14 °C			
Compressor (q.ty - type) Compressore (q.tà - tipologia)	1 - Hermetic 1 - Ermetico			
Defrost Sbrinamento	Hot gas Gas caldo			
Power supply Alimentazione	230 V / 1 Ph / 50 Hz			
Electrical input (nominal) Assorbimento elettrico (regime)	555 W / 2,5 A	900 W / 4,1 A	980 W / 4,5 A	
Electrical input (defrost) Assorbimento elettrico (sbrinamento)	1425 W / 6,5 A	1860 W / 7,5 A	1960 W / 8,3 A	

Technical sheet about models whit condensing unit included with air cooled
Dati tecnici riferiti a modelli con unità a bordo con condensazione ad aria

Setup
Allestimento

5 Lt * 360 x 165 x 120 h		4 + (4) 	6 + (6) 	7 + (7) 	9 + (9) 
4,75 Lt 260 x 157 x 170 h		4 	6 	7 	9 

* Piled up double row Doppia fila di riserva

Item
Accessorio

White cone holder Portaconi completo bianco	•
Scoop washer with stainless steel container Lavaporzionatore vaschetta inox	•

120	140
1214x785x1247 mm	1354x785x1247 mm
459 / 243 Lt	518 / 274 Lt
110 kg	135 kg
Ventilated Ventilata	
R290	
7	
35 °C / 75 %RH	
-16/-14 °C	
1 - Hermetic 1 - Ermetico	
Hot gas Gas caldo	
230 V / 1 Ph / 50 Hz	
950 W / 4,3 A	1000 W / 4,5 A
2000 W / 8 A	2050 W / 8,4 A





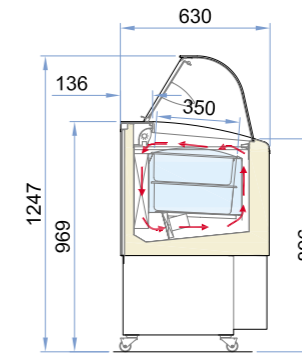

Display - piled up double row - 5 Lt
Vasca espositiva - doppia fila di riserva - 5 Lt

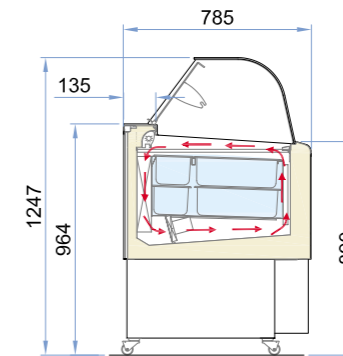

4 - 6 - 7 - 9



120 - 140

9 + (9) 	10 + (10) 
12 	14 

Bermuda LX

H 134
P 80
L 10 • 13

Gelato

	TN Chiller	TB Freezer	TB/TN Dual Temp
RS-Static			
RV-Ventilated		•	
TCS-Heated			
CH-Chocolate			

Installation Plug-in	Front glass Heated
Temperature -16/-14 °C	Side glass Tempered
Refrigerant R290	Rear closing system Self-rolling curtain
Refrigeration Ventilated	Work top Prepainted sheet Grey RAL 9006
Compressor Hermetic	Lighting Led 5700 K
Defrost Hot gas	Equipment handling Swivel casters with brake
Climate class 4	Storage cell Static refrigerated with skin evaporator
Upper class Tempered	

Installazione Plug-in	Temperatura -16/-14 °C
Refrigerante R290	Refrigerazione Ventilata
Compressore Ermetico	Sbrinamento Gas caldo
Classe climatica 4	Classe climatica 4
Vetro superiore Temperato	

Vetro frontale Riscaldato	Internal color Colore interno
Vetri laterali Temperato	<input type="checkbox"/> White
Chiusura posteriore Tenda manuale autoavvolgente	Sides color Colore fianchi
Piano di servizio Lamiera preverniciata Grigio RAL 9006	<input checked="" type="checkbox"/> Grigio E_Z065
Illuminazione Led 5700 K	
Movimentazione Ruote pivotanti con freno	
Cella di riserva Refrigerata statica con evaporatore a mantello	



PM_AD7_BM

Front sticker (standard)
Adesivo frontale



Bermuda LX	10	13
External dimensions (LxDxH) Dimensioni esterne (LxPxH)	1340x799x1343 mm	1670x799x1343 mm
Capacity (gross/net) Capacità (lorda/netta)	300 / 255 Lt	395 / 325 Lt
Net weight Peso netto	190 kg	200 kg
Refrigeration Refrigerazione	Ventilated Ventilata	
Refrigerant Refrigerante	R290	
Climate class Classe climatica	4	
Operating conditions Condizioni ambientali	30 °C / 55 %RH	
Product temperature Temperatura prodotto	-16/-14 °C	
Compressor (q.ty - type) Compressore (q.tà - tipologia)	1 - Hermetic 1 - Ermetico	2 - Hermetics 2 - Ermetici
Defrost Sbrinamento	Hot gas Gas caldo	
Power supply Alimentazione	230 V / 1 Ph / 50 Hz	
Electrical input (nominal) Assorbimento elettrico (regime)	770 W / 4,3 A	1340 W / 6,7 A
Electrical input (defrost) Assorbimento elettrico (sbrinamento)	1410 W / 6,9 A	2200 W / 10,4 A

Technical sheet about models whit condensing unit included with air cooled
Dati tecnici riferiti a modelli con unità a bordo con condensazione ad aria

Setup
Allestimento

Display
Vasca espositiva

5 Lt 360 x 165 x 120 h		10	13
4,75 Lt 260 x 157 x 170 h		14	18

Storage cell
Cella di riserva

5 Lt * 360 x 165 x 120 h		4 + (4)	6 + (6)
4,75 Lt 260 x 157 x 170 h		6	8

* Piled up double row Doppia fila di riserva



Storage cell
Cella di riserva

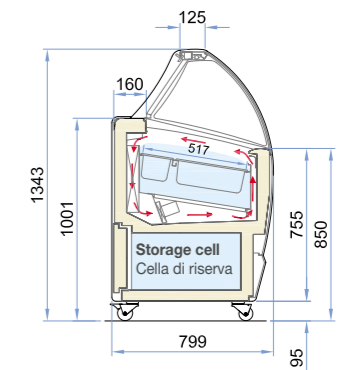

Bermuda View

H 135
P 81
L 10 • 13

Gelato

	TN Chiller	TB Freezer	TB/TN Dual Temp
RS-Static			
RV-Ventilated		•	
TCS-Heated			
CH-Chocolate			

Installation
Plug-in

Temperature
-16/-14 °C

Refrigerant
R290

Refrigeration
Ventilated

Compressor
Hermetic

Defrost
Hot gas

Climate class
7

Upper class
Tempered

Front glass
Heated

Side glass
Tempered

Opening system
Downward-opening

Rear closing system
Self-rolling curtain

Work top
Prepainted sheet
Grey RAL 9006

Lighting
Led 5700 K

Equipment handling
Swivel casters
with brake

Storage cell
Static refrigerated
with skin evaporator

Installazione
Plug-in

Temperatura
-16/-14 °C

Refrigerante
R290

Refrigerazione
Ventilata

Compressore
Ermetico

Sbrinamento
Gas caldo

Classe climatica
7

Vetro superiore
Temperato

Vetro frontale
Riscaldato

Vetri laterali
Temperato

Apertura anteriore
Apertura manuale
verso il basso

Chiusura posteriore
Tenda manuale autoavvolgente

Piano di servizio
Lamiera preverniciata
Grigio RAL 9006

Illuminazione
Led 5700 K

Movimentazione
Ruote pivotanti
con freno

Cella di riserva
Refrigerata statica con
evaporatore a mantello

Internal color
Colore interno

White

Front color
Colore frontale

White

Sides color
Colore fianchi

White



Bermuda View

10 13

External dimensions (LxDxH) Dimensioni esterne (LxPxH)	1340x814x1354 mm	1670x814x1354 mm
Capacity (gross/net) Capacità (lorda/netta)	300 / 255 Lt	395 / 325 Lt
Net weight Peso netto	195 kg	235 kg
Refrigeration Refrigerazione	Ventilated Ventilata	
Refrigerant Refrigerante	R290	
Climate class Classe climatica	7	
Operating conditions Condizioni ambientali	35 °C / 75 %RH	
Product temperature Temperatura prodotto	-16/-14 °C	
Compressor (q.ty - type) Compressore (q.tà - tipologia)	2 - Hermetics 2 - Ermetici	
Defrost Sbrinamento	Hot gas Gas caldo	
Power supply Alimentazione	230 V / 1 Ph / 50 Hz	
Electrical input (nominal) Assorbimento elettrico (regime)	1250 W / 5,8 A	1600 W / 8 A
Electrical input (defrost) Assorbimento elettrico (sbrinamento)	1360 W / 6,6 A	2000 W / 10 A

Technical sheet about models with condensing unit included with air cooled
Dati tecnici riferiti a modelli con unità a bordo con condensazione ad aria

Setup
Allestimento

Display
Vasca espositiva

5 Lt
360 x 165 x 120 h



10

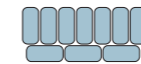

13

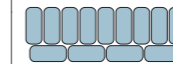

Storage cell
Cella di riserva

5 Lt
360 x 165 x 120 h



4

6

Item
Accessorio

White cone holder
Portaconi completo bianco

•

Scoop washer with stainless steel container
Lavaporzionatore vaschetta inox

•



Storage cell
Cella di riserva

